



GAI-TRONICS®
A HUBBELL COMPANY

ICS Page/Party® AC Plug-in Amplifiers

Quick Installation Guide

Important Safety Instructions

- This equipment is suitable for use in Class I, Division 2, Groups A, B, C and D, Class II Division 2, Groups F, and G, Class III, OR non-hazardous locations only. Combinations of equipment in each system is subject to investigation by the local authority at the time of installation.
- **Read, follow, and retain instructions**—Read and follow all safety and operating instructions before installing or operating this unit. Retain instructions for future reference.
- **Heed warnings**—Adhere to all warnings on the unit and in the operating instructions.
- **Attachments**—Do not use attachments not recommended by the product manufacturer, as they may cause hazards. Maximum system cable length is not to exceed two miles.
- **Servicing**—Do not attempt to service this unit. Opening or removing covers may expose dangerous voltage or other hazards. Refer all servicing to qualified service personnel.

This permanently connected apparatus must have a UL listed 15-amp circuit breaker incorporated in the electrical installation of the building.

⚠ WARNING ⚠ —EXPLOSION HAZARD—Do not disconnect equipment before removing power and verifying the area is non-hazardous. Avertissement—Risque d'explosion—avant de déconnecter l'équipement, couper le courant ou s'assurer que l'emplacement est désigné non dandereux.

USA and Canada—Consult the National Electrical Code (NFPA 70), Canadian Standards Association (CSA 22.1), and local codes for specific requirements regarding your installation. Install Class 2 circuit wiring in accordance with NEC 725.55.

General Information and Available Options

This quick guide covers the installation of the ICS AC Plug-in Amplifiers. See the chart below for applicable models.

ICS Amplifier Model	Description
751-001ICS	Speaker Amplifier
701-302ICS	Handset/Speaker Amplifier
701-304ICS	Handset/Speaker Amplifier with Auxiliary Jack
751-001ICSVC	Speaker Amplifier with VLC
701-302ICSVC	Handset/Speaker Amplifier with VLC
701-304ICSVC	Handset/Speaker Amplifier with Auxiliary Jack and VLC
751-901ICS	SmartSeries Speaker Amplifier
701-902ICS	SmartSeries Handset/Speaker Amplifier
701-904ICS	SmartSeries Handset/Speaker Amplifier with Auxiliary Jack
723-901ICS	SmartSeries Remote Handset/Speaker Amplifier

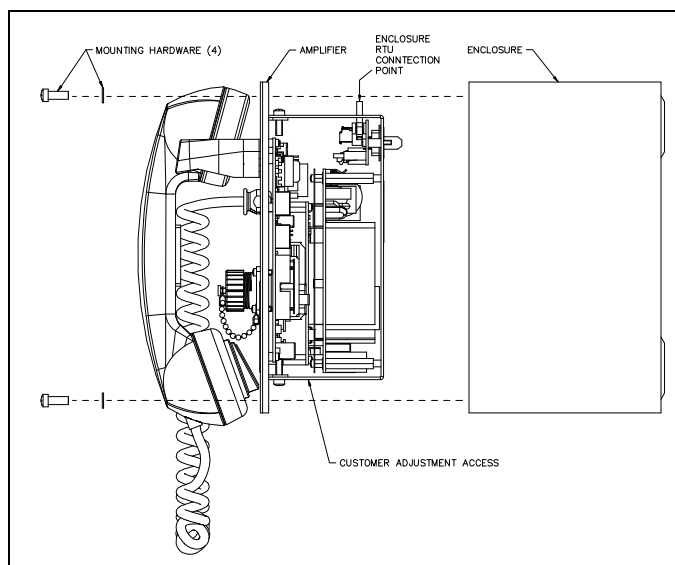

Figure 1. ICS AC Page/Party® Plug-in Amplifier Installation

Refer to Pub. 42004-730 on the resources tab of GAI-Tronics' website at <https://www.hubbell.com/gai-tronics/en> for detailed explanations of the available models and their settings, adjustments, and warranty.

ICS Page/Party Plug-in Amplifier Installation

1. Plug the amplifier directly into the enclosure. Use extra care to prevent damage to the protruding latch wings of connector P6, located on the top right edge of the amplifier, during installation.
2. Attach the amplifier to the enclosure with the provided hardware (see [Figure 1](#)).
3. Apply power to the station.

Enclosure RTU Connection (if applicable)

Connect amplifiers with VLC or SmartSeries PCBAs to an RTU enclosure using the provided ribbon cable to use the double-pole, Form C relay and one fuse-protected contact. If an RTU is present in the enclosure, connect the provided ribbon cable to the receptacle, on the top side of the amplifier.

Available Adjustments

The factory preconfigures most models to default settings. The following is a partial list of available settings and adjustments. Refer to Pub. 42004-730 for complete information.

Standard AC-Powered ICS Plug-in Amp	ICS Plug-in Amp with VLC	SmartSeries AC-Powered Plug-in Amp
<ul style="list-style-type: none"> • Speaker Volume • Speaker Mute • Speaker Gain • Transmit Level • Receiver Volume 	<ul style="list-style-type: none"> • Speaker Volume • Speaker Mute • Speaker Gain • Transmit Level • Receiver Volume • Audio Alignment • Page Disable Control • Remote Signaling (RTU) 	<ul style="list-style-type: none"> • Address • ALS Minimum Level • ALS Offset Level • SmartSeries VLC Level • FSK Signal Gain

Table 1. Approvals by Amplifier and Enclosure

Temperature code, T4

Amplifier Model	Enclosure			
	702/703 Series	733/7335 Series	732, 7325, 733, 7335, 758 Series	7245 Series
701-302ICS	See Note 1	N/A	See Note 2	N/A
701-302ICSV		N/A		N/A
701-304ICS		N/A		N/A
701-304ICSV		N/A		N/A
751-001ICS		N/A		N/A
751-001ICSV		N/A		N/A
701-902ICS	N/A	See Note 1	N/A	N/A
701-904ICS	N/A		N/A	
751-901ICS	N/A		N/A	
723-901ICS	N/A	N/A	N/A	See Note 3

NOTE 1: Class I, Div. 2, Groups A, B, C and D

NOTE 2: Class I, Div. 2, Groups A, B, C and D;
Class II, Div. 2, Groups F and G;
Class III, Division 2

NOTE 3: UL/CSA 60950

Warranty

Equipment. GAI-Tronics warrants for a period of one (1) year from the date of shipment, that any GAI-Tronics equipment supplied hereunder shall be free of defects in material and workmanship, shall comply with the then-current product specifications and product literature, and if applicable, shall be fit for the purpose specified in the agreed-upon quotation or proposal document. If (a) Seller's goods prove to be defective in workmanship and/or material under normal and proper usage, or unfit for the purpose specified and agreed upon, and (b) Buyer's claim is made within the warranty period set forth above, Buyer may return such goods to GAI-Tronics' nearest depot repair facility, freight prepaid, at which time they will be repaired or replaced, at Seller's option, without charge to Buyer. Repair or replacement shall be Buyer's sole and exclusive remedy. The warranty period on any repaired or replacement equipment shall be the greater of the ninety (90) day repair warranty or one (1) year from the date the original equipment was shipped. In no event shall GAI-Tronics warranty obligations with respect to equipment exceed 100% of the total cost of the equipment supplied hereunder. Buyer may also be entitled to the manufacturer's warranty on any third-party goods supplied by GAI-Tronics hereunder. The applicability of any such third-party warranty will be determined by GAI-Tronics.

Services. Any services GAI-Tronics provides hereunder, whether directly or through subcontractors, shall be performed in accordance with the standard of care with which such services are normally provided in the industry. If the services fail to meet the applicable industry standard, GAI-Tronics will re-perform such services at no cost to buyer to correct said deficiency to Company's satisfaction provided any and all issues are identified prior to the demobilization of the Contractor's personnel from the work site. Re-performance of services shall be Buyer's sole and exclusive remedy, and in no event shall GAI-Tronics warranty obligations with respect to services exceed 100% of the total cost of the services provided hereunder.

Warranty Periods. Every claim by Buyer alleging a defect in the goods and/or services provided hereunder shall be deemed waived unless such claim is made in writing within the applicable warranty periods as set forth above. Provided, however, that if the defect complained of is latent and not discoverable within the above warranty periods, every claim arising on account of such latent defect shall be deemed waived unless it is made in writing within a reasonable time after such latent defect is or should have been discovered by Buyer.

Limitations / Exclusions. The warranties herein shall not apply to, and GAI-Tronics shall not be responsible for, any damage to the goods or failure of the services supplied hereunder, to the extent caused by Buyer's neglect, failure to follow operational and maintenance procedures provided with the equipment, or the use of technicians not specifically authorized by GAI-Tronics to maintain or service the equipment. **THE WARRANTIES AND REMEDIES CONTAINED HEREIN ARE IN LIEU OF AND EXCLUDE ALL OTHER WARRANTIES AND REMEDIES, WHETHER EXPRESS OR IMPLIED BY OPERATION OF LAW OR OTHERWISE, INCLUDING ANY WARRANTIES OF MERCHANTABILITY OR FITNESS FOR A PARTICULAR PURPOSE.**

Return Policy

If the equipment requires service, contact your Regional Service Center for a return authorization number (RA#). Equipment should be shipped prepaid to GAI-Tronics with a return authorization number and a purchase order number. If the equipment is under warranty, repairs or a replacement will be made in accordance with the warranty policy set forth above. Please include a written explanation of all defects to assist our technicians in their troubleshooting efforts.

Call 800-492-1212 (inside the USA) or 610-777-1374 (outside the USA) for help identifying the Regional Service Center closest to you.